

timber roller shutter security with style

APPLICATIONS -

Reception Desks Bar Tops Counter Tops Doorways

Opening size: 2400mm (W) x 2400mm (H)

FEATURES - Custom made from the timber of your choice in either polished or untreated finish to blend in with surrounding architecture. Doors are supplied with either timber or aluminium side guides to suit specific requirements

SPECIFICATIONS

Curtain - Machined timber slats with a face depth of 38mm x 16mm thick with specially designed self mating edge profiles to allow rolling and provide a continuous timber appearance.

Side Guides - 50mm x 40mm marching timber with 20mm x 20mm rebate for curtain travel or 37mm x 25mm extruded aluminium with schlegal nylofelt buffer for noise reduction and curtain protection.

Locking - Two way mortise key lock or sliding shoot bolts.

Bottom Rail - 75mm x 16mm timber profile designed to mate with slats fitted with 65mm x 5mm timber cover plate to conceal lock and locking bars. A 40mm x 12mm full radius timber profile is fitted to base to form a "Tee".

Brackets - manufactured from 90mm x 40mm mild steel.

Roller Drum - manufactured from 165mm or 229 mm spiral ducted tube attached to self lubrication drum wheels and bearing rotating on a 34mm steel shaft. The shaft shall be fitted with helical springs designed to counterbalance the curtain throughout its operation. The drum shall be designed to give minimum deflection over the span.

Mullions - Either two piece aluminium or machined timber to match curtain designed specifically to suit the installation.

Operation - Designed for manual operation or motorised.

Sliding - Manual sliding operation available depending on size and path complexity.

Finish - Stained and / or polished or untreated.

BUNDLE DIAMETERS

Drop	900	1200	1500	1800	2100	2400
150mm	230	245	260	260	275	290
229mm	275	295	295	315	330	330

Monarch Group Pty Ltd has a continuous program of product development, sizes and configurations may change, for up to the minute specifications, please call us.



MONARCH GROUP PTY LTD

SYDNEY OFFICE

58 Box Road Taren Point NSW 2229
Phone: (02) 9526 1222 Fax: (02) 9525 1114

BRISBANE OFFICE

56-58 Nestor Drive Meadowbrook QLD 4131
Phone: (07) 3805 7314 Fax: (07) 3805 7315

timber roller shutter security with style

BULKHEAD DETAILS

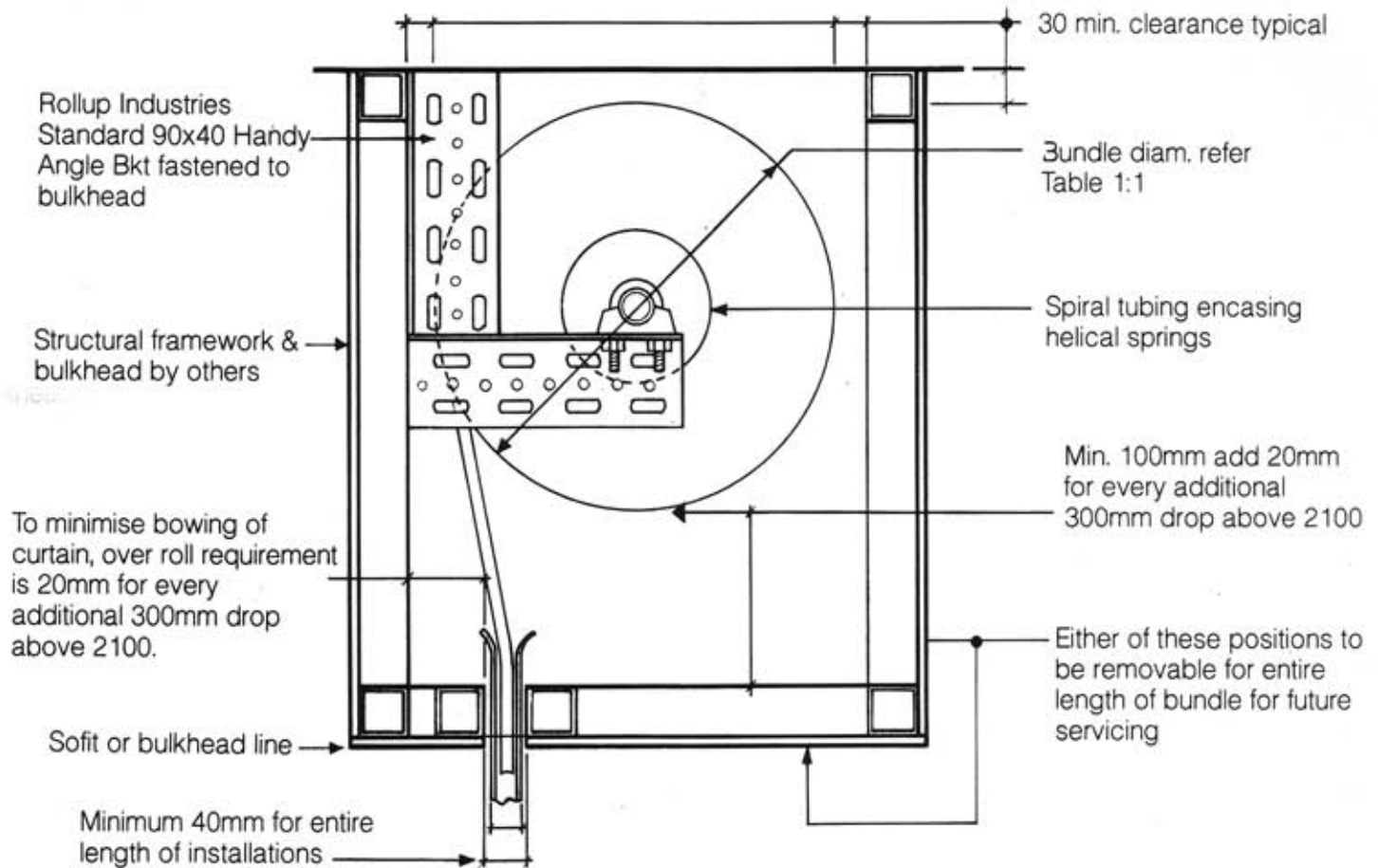

STANDARD INSTALLATION DETAILS

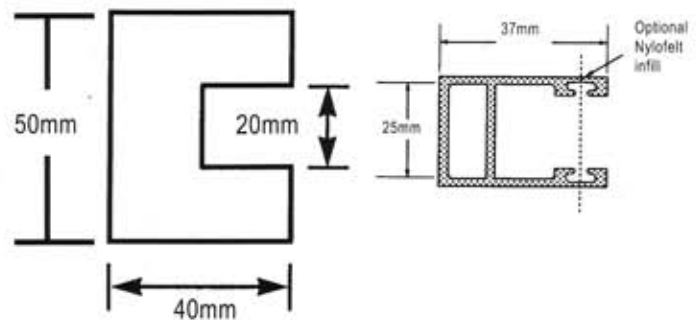
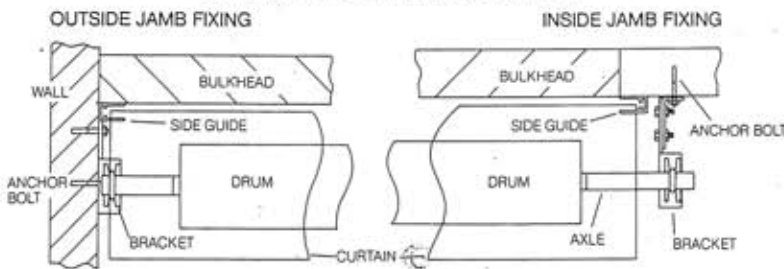

Monarch Group Pty Ltd has a continuous program of product development, sizes and configurations may change, for up to the minute specifications, please call us.



MONARCH GROUP PTY LTD

SYDNEY OFFICE
58 Box Road Taren Point NSW 2229
Phone: (02) 9526 1222 Fax: (02) 9525 1114

BRISBANE OFFICE
56-58 Nestor Drive Meadowbrook QLD 4131
Phone: (07) 3805 7314 Fax: (07) 3805 7315